

A I R Κ Λ Ι Μ Α Τ Ι Σ Τ Ι Κ Α Σ Υ Σ Τ Η Μ Α Τ Α Σ
C O N D I T I O N I N G S Y S T E M S

Models: A2MVI-09 / A2MVO-09
A2MVI-12 / A2MVO-12
A2MVI-18 / A2MVO-18
A2MVI-24 / A2MVO-24
P2MVI-09 / P2MVO-09
P2MVI-12 / P2MVO-12
P2MVI-18 / P2MVO-18
P2MVI-24 / P2MVO-24

Wall Mounted Unit

Installation Manual

Επιτοίχια Μονάδα

Εγχειρίδιο Εγκατάστασης

Σας ευχαριστούμε που επιλέξατε τη μονάδα κλιματισμού της INVENTOR. Για τη σωστή χρήση της μονάδας, παρακαλούμε διαβάστε προσεκτικά το παρόν εγχειρίδιο και φυλάξτε το για αναφορά στο μέλλον.

Thank you for choosing INVENTOR air conditioning system. For correct use of this unit, please read this manual carefully and keep it for future reference.

English/Ελληνικά/ Română

 **inventor**[®]
Your-conditions

INSTALLATION MANUAL FOR ROOM AIR CONDITIONER (Split Wall-Mounted Type)

INSTALLATION PRECAUTIONS

- Please read this installation manual carefully before operating the unit to ensure correct installation.
- If the power cord is damaged, replacement work shall be performed by authorised personnel only.
- Installation work must be performed in accordance with the national wiring standards by authorised personnel only.
- Contact an authorized service technician for repair, maintenance and installation of this unit.
- This appliance is not intended for use by persons (including children) with reduced physical, sensory or mental capabilities, or lack of experience and knowledge, unless they have been given supervision or instruction concerning use of the appliance by persons responsible for their safety.
- Children should be supervised to ensure that they do not play with the appliance.
- All the pictures in the instructions are for explanation purposes only. The actual shape should prevail.
- The design and specifications are subject to change without prior notice for product improvement. Consult with the sales agency or manufacturer for details.

SAFETY PRECAUTIONS

- Please read these safety precautions carefully before installation
- Be sure to follow all the precautions below, they are all important for ensuring safety.

	WARNING This symbol indicates the possibility of death or serious injury.
	CAUTION This symbol indicates the possibility of injury or damage to property.

WARNING

- 1) Install according to this installation instructions strictly. If installation is defective, it will cause water leakage, electrical shock, or fire.
- 2) Use the included accessories parts and specified parts for installation. otherwise, it will cause the set to fall, water leakage, electrical shock, or fire.
- 3) Install at a strong and firm location which is able to withstand the set's weight. If the strength is not enough or installation is not properly done, the set will drop and cause injury.
- 4) For electrical work, follow the local national wiring standard, regulation and this installation instructions. An independent circuit and single outlet must be used. If electrical circuit capacity is not enough or defect found in electrical work, it will cause electrical shock, or fire.
- 5) Use the specified cable and connect tightly and clamp the cable so that no external force will be acted on the terminal. If connection or fixing is not perfect, it will cause heat-up or fire at the connection.
- 6) Wiring routing must be properly arranged so that control board cover is fixed properly. If control board cover is not fixed perfectly, it will overheat at connection point of terminal, fire or electrical shock.
- 7) When carrying out piping connection, take care not to let air substances other than the specified refrigerant go into refrigeration cycle. Otherwise, it will cause lower capacity, abnormal high pressure in the refrigeration cycle, explosion and injury.
- 8) Do not modify the length of the power supply cord or use of extension cord, and do not share the single outlet with other electrical appliances. Otherwise, it will cause fire or electrical shock.

CAUTION

- 1) This equipment must be grounded and installed with ground leakage current breaker. It may cause electrical shock if grounding is not perfect.
- 2) Do not install the unit at place where leakage of flammable gas may occur. In case gas leaks and accumulates at surrounding of the unit, it may cause fire.
- 3) Carry out drainage piping as mentioned in installation instructions. If drainage is not perfect, water may enter the room and damage the furniture.

SELECT THE BEST LOCATION

Indoor unit

- There should not be any heat source or stream near the unit.
- There should not be any obstacles blocking the air circulation.
- A place where air circulation in the room is good.
- A place where drainage can be easily done.
- A place where noise prevention is taken into consideration.
- Do not install the unit near the door way.
- Ensure the spaces indicated by arrows from the wall, ceiling, fence or other obstacles.
- There should not be any direct sunlight. If unavoidable, sunlight prevention should be taken into consideration.

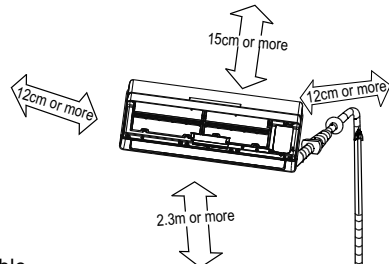

Outdoor unit

- If an awning is built over the unit to prevent direct sunlight or rain, be careful that heat radiation from the condenser is not obstructed.
- There should not be any animal or plant which could be affected by hot air discharged.
- Keep the spaces indicated by arrow from wall ceiling, fence or other obstacles.
- Do not place any obstacles which may cause a short circuit of the discharged air.

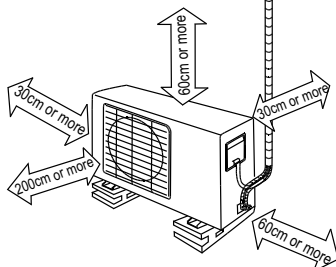

Settlement of outdoor unit

- Anchor the outdoor unit with a bolt and nut $\phi 10$ or $\phi 8$ tightly and horizontally on a concrete or rigid mount.
- NOTE:** The outdoor unit you purchase may be like one of the following. Install the outdoor unit according to the dimension as indicated in the table below:

Outdoor unit dimension mm (WxHxD)	Mounting dimensions	
	A (mm)	B (mm)
700x540x240	458	250
685x430x260	460	276
780x540x250	549	276
760x590x285	530	290
845x700x320	560	335
810x558x310	549	325
670x540x265	481	276

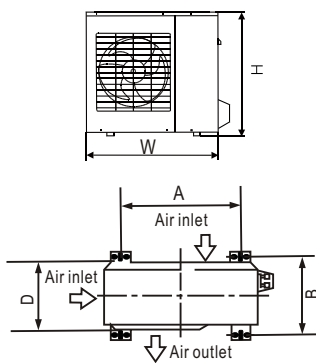

ACCESSORIES

Number	Name of Accessories	Qty	
1	Installation Plate	1	
2	Clip Anchor	5-8 (depending on models)	
3	Self-tapping Screw AST3.9x25	5-8 (depending on models)	
4	Seal (For cooling & heating models only)	1	
5	Drain Joint (For cooling & heating models only)	1	
6	Connecting pipe Assembly	Liquid side $\phi 6.35$	Parts you must purchase. The pipe size differ from appliance to appliance. Consult the technician for the proper size.
		Liquid side $\phi 9.52$	
		Gasside $\phi 9.52$	
		Gasside $\phi 12.7$	
7	Remote controller	1	
8	Self-tapping Screw B ST2.9x10	2	
9	Remote controller holder	1	
10	Air freshening filter (used to install on Air filter)	1	

NOTE: Except the above parts provided, the other parts needed during installation you must purchase.

1 INSTALLATION PLATE MOUNTING

NOTE:

The mounting wall is strong and solid enough to prevent it from the vibration.

Installation Plate Mounting

1. Fit the installation plate horizontally on structural parts of the wall with spaces around the installation plate.
2. If the wall is made of brick, concrete or the like, drill five or eight 5mm diameter holes in the wall. Insert Clip anchor for appropriate mounting screws.
3. Fit the installation plate on the wall with five or eight type "A" screws.

NOTE:

Mount the Installation Plate and drill holes in the wall according to the wall structure and corresponding mounting points on the installation plate. The installation plate provided with the machine differ from appliance to appliance.

(Dimensions are in "mm" unless otherwise stated)

Correct orientation of Installation Plate

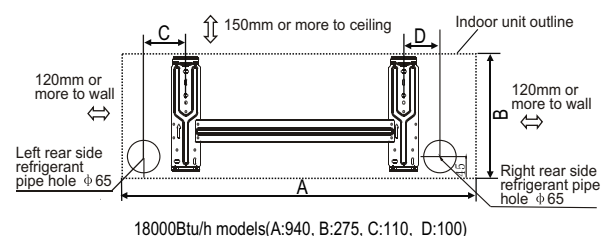
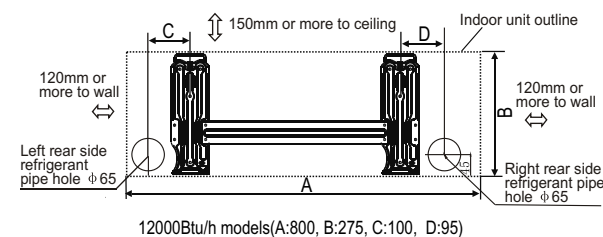
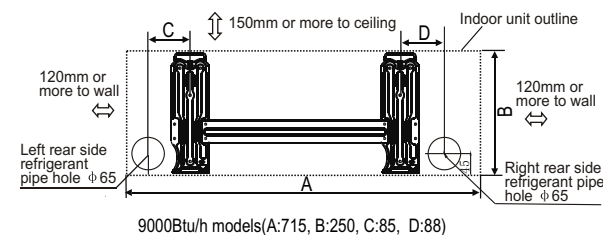
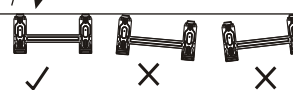

2 DRILL A HOLE IN THE WALL

1. Determine hole positions according to left and right side of the installation plate. The hole center is obtained by measuring the distance as shown in the diagram above.
2. Drill the piping hole with $\phi 65$ mm hole-core drill.
3. Drill the piping hole at either the right or the left and the hole should be slightly slanted to the outdoor side.
4. Always take steps to protect the pipe when drilling metal grid, metal plate or the like.

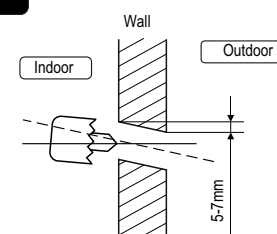

3 CONNECT THE CABLE TO THE INDOOR UNIT

Electrical work

Electric safety regulations for the initial installation

1. If there is serious safety problem about the power supply, the technicians should refuse to install the air conditioner and explain to the client until the problem is solved.
2. Power voltage should be in the range of 90%~110% of rated voltage.
3. The surge protector and main power switch with a 1.5 times capacity of Max. Current of the unit should be installed in power circuit. Ensure the air conditioner is grounded well.
4. The appliance shall be installed in accordance with national wiring regulations. Do not operate your air conditioner in a wet room such as a bathroom or laundry room.
5. An all-pole disconnection device which has at least 3mm clearances in all poles, and have a leakage current that may exceed 10mA, the residual current device (RCD) having a rated residual operating current not exceeding 30mA, and disconnection must be incorporated in the fixed wiring in accordance with the wiring rules.
6. For the unit adopts auxiliary electric heater, keep at least 1 meter away from the nearest combustible materials.
7. According to the attached Electrical Connection Diagram located on the panel of the indoor & outdoor unit to connect the wire.
8. All wiring must comply with local and national electrical codes and be installed by qualified and skilled electricians.
9. An individual branch circuit and single receptacle used only for this air conditioner must be available. See the following table for suggested wire sizes and fuse specifications:

Minimum cross-sectional area of conductors:

Rated current of appliance (A)	Nominal cross-sectional area (mm ²)
>3 and ≤6	0.75
>6 and ≤10	1
>10 and ≤16	1.5
>16 and ≤25	2.5
>25 and ≤32	4
>32 and ≤40	6

NOTE:

- The wire size of power supply cord and interconnected wire and the current of the fuse or switch are determined by the maximum current indicated on the nameplate which located on the side panel of the unit. Please refer to the nameplate before selecting the wire size, fuse or switch.
- The controller of the air conditioner designed with a fuse protection function under abnormal conditions, the specifications of the fuse have printed on the circuit board, such as: T3.15A/250VAC, T5A/250VAC, etc.

Connect the cable to the indoor unit

NOTE: Before performing any electrical work, turn off the main power to the system.

1. The inside and outside connecting cable can be connected without removing the front grille.
 2. The indoor power cord type is H05VV-F or H05V2V2-F, the outdoor power cord and interconnected cord type is H07RN-F.
 3. Lift the indoor unit panel up, remove the electrical box cover by loosening the screw.
 4. Ensure the colour of wires of outdoor unit and the terminal Nos. are the same to the indoor's respectively.
 5. Wrap those cables not connected with terminals with insulation tapes, so that they will not touch any electrical components. Secure the cable onto the control board with the cord clamp.
- NOTE:** If used as MONO unit, for the standby control needs, the cross section area of cable connected to L(1)/W, 1/1(L), 2(N) must be sufficient for the maximum system current. The maximum system current is equal to the sum of indoor unit and outdoor unit rated current. If used as MULTI unit, L(1)/W on the terminal block does not need to be connected.

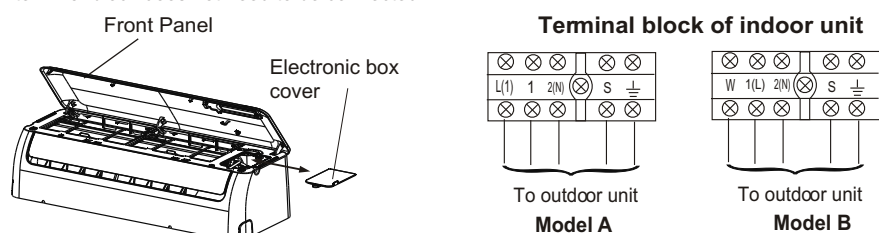

4 CONNECTIVE PIPE AND DRAINAGE INSTALLATION

Drainage

1. Run the drain hose sloping downward. Do not install the drain hose as illustrated in wrong figures.
2. When connecting extension drain hose, insulate the connecting part of extension drain hose with a shield pipe, do not let the drain hose slack.

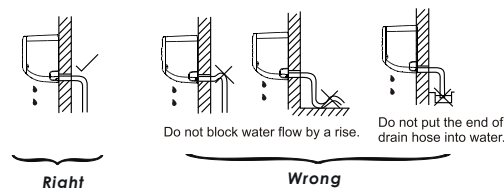

Connective pipe installation

- For the left-hand and right-hand piping, remove the pipe cover from the side panel.
- For the right back and left back piping, install the piping as shown.

NOTE: Both sides drainage structure is standard. For both sides drainage structure, it can be chosen for right, left or both sides drainage connection. If choosing both sides drainage connection, another proper drain hose is needed as there is only one drain hose offered by factory. If choosing one side drainage connection, make sure the drain hole on the other side is well plugged. For 9k/12k models, if choosing left-hand or left-back piping, please choosing left side drainage connection. The connection of the drain hose is supposed to be done by qualified installer in case of water leakage.

- Bundle the tubing, connecting cable, and drain hose with tape securely, evenly as shown in Figure on the right.

CAUTION

- Connect the indoor unit first, then the outdoor unit.
- Do not allow the piping to let out from the back of the indoor unit.
- Be careful not to let the drain hose slack.
- Heat insulation should be done to the extension drain hose of indoor unit.
- Be sure that the drain hose is located at the lowest side of the bundle. Locating at the upper side can cause drain pan to overflow inside the unit.
- Never intercross nor intertwist the power wire with any other wiring.

Indoor unit installation

- Pass the piping through the hole in the wall.
- Hook the indoor unit onto the upper portion of installation plate (Engage the indoor unit with the upper edge of the installation plate). Ensure the hooks are properly seated on the installation plate by moving it in left and right.
- Piping can easily be made by lifting the indoor unit with a cushioning material between the indoor unit and the wall. Get it out after finish piping.
- Press the lower left and right side of the unit against the installation plate until hooks engages with the their slots.

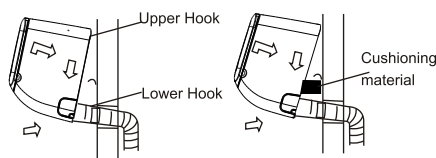
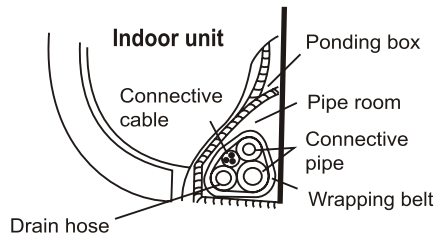
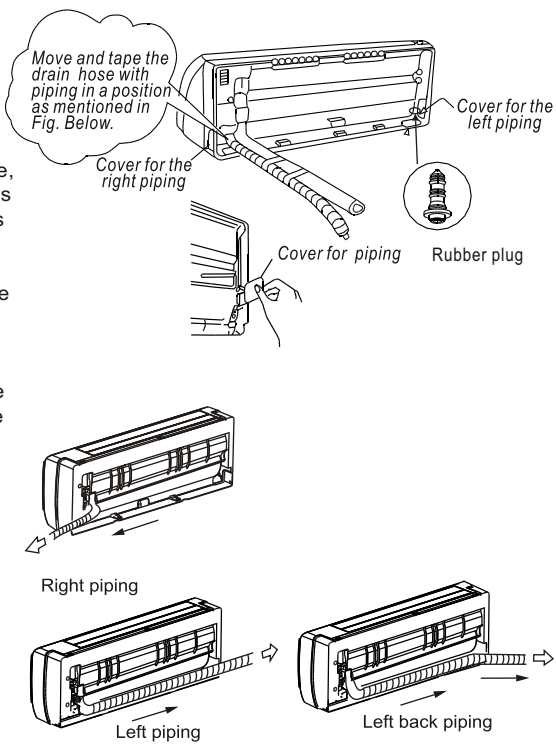

4 CONNECT THE CABLE TO THE OUTDOOR UNIT

- Remove the electrical control board cover from the outdoor unit by loosening the screw.
- Connect the connective cables to the terminals as identified with their respective matched numbers on the terminal block of indoor and outdoor units.
- Secure the cable onto the control board with the cord clamp.
- To prevent the ingress of water, form a loop of the connective cable as illustrated in the installation diagram of indoor and outdoor units.
- Insulate unused cords (conductors) with PVC-tape. Process them so they do not touch any electrical or metal parts.

Terminal block of outdoor unit

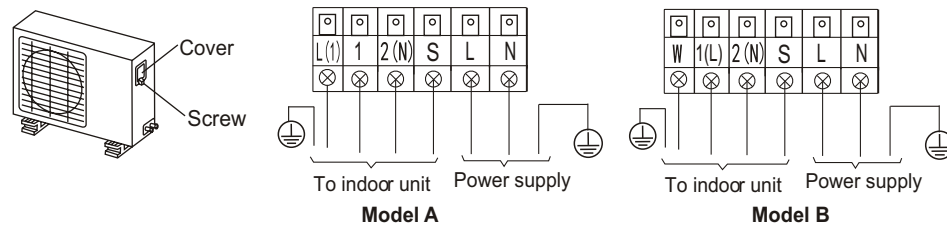

5 AIR PURGING AND TEST OPERATION

NOTE: Connective pipe length will affect the capacity and energy efficiency of the unit. The nominal efficiency is tested basing on the pipe length of 5 meters.

1. Airpurging

- The indoor unit and tubing between the indoor and outdoor unit must be leak tested and evacuated to remove any noncondensables and moisture from the system.
- Check that each tube (both liquid and gas side tubes) between the indoor and outdoor units have been properly connected and all wiring for the test run has been completed.
- Pipe length and refrigerant amount:

Connective pipe length	Air purging method	Additional amount of refrigerant to be charged	
Less than 5m	Use vacuum pump	---	
More than 5m	Use vacuum pump	Liquid side: ϕ 6.35mm R22: (Pipe length-5)x30g/m R410A: (Pipe length-5)x20g/m	Liquid side: ϕ 9.52mm: R22: (Pipe length-5)x60g/m R410A: (Pipe length-5)x40g/m

- For the R410A refrigerant model, make sure the refrigerant added into air conditioner is liquid form in any cases.
- When relocating the unit to another place, using vacuum pump to perform evacuation.

CAUTION

- Open the valve stem until it hits against the stopper. Do not try to open it further.
- Securely tighten the valve stem cap with a spanner or the like.
- Valve stem cap tightening torque. See Tightening torque table.

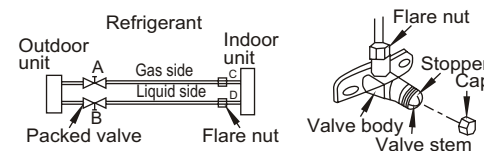

2. When using the Vacuum Pump

- Completely tighten the flare nuts, A, B, C, D, connect the manifold valve charge hose to a charge port of the packed valve on the gas pipe side.
- Connect the charge hose connection to the vacuum pump.
- Fully open the handle Lo of the manifold valve.
- Operate the vacuum pump to evacuate. After starting evacuation, slightly loose the flare nut of the packed valve on the gas pipe side and check that the air is entering. (Operation noise of the vacuum pump changes and a compound meter indicates 0 instead of minus)
- After the evacuation is complete, fully close the handle Lo of the manifold valve and stop the operation of the vacuum pump.
- Make evacuation for 15 minutes and more and check that the compound meter indicates -76cmHg ($-1.0 \times 10^5 \text{Pa}$).
- Turn the stem of the packed valve B about 45° counter-clockwise for 6~7 seconds after the gas coming out, then tighten the flare nut again. Make sure the pressure display in the pressure indicator is a little higher than the atmosphere pressure.
- Remove the charge hose from the Low pressure charge hose.
- Fully open the packed valve stems B and A.
- Securely tighten the cap of the packed valve.

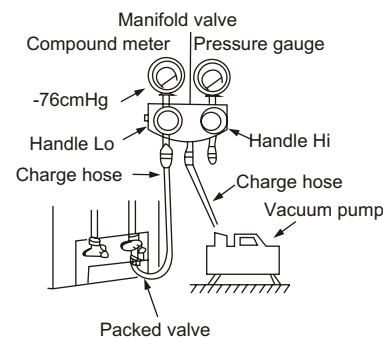

3. Safety and leakage check

- Soap water method:**
Apply a soap water or a liquid neutral detergent on the indoor unit connections and outdoor unit connections by a soft brush to check for leakage of the connecting points of the piping. If bubbles come out, it indicates that the pipes have leakage.
- Leak detector**
Use the leak detector to check for leakage.

CAUTION

A: Lo packed valve B: Hi packed valve
C and D are ends of indoor unit connection.

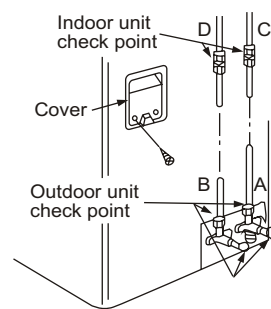

4. Test running

Perform test operation after completing gas leak check at the flare nut connections and electrical safety check.

- Check that all tubing and wiring have been properly connected.
 - Check that the gas and liquid side service valves are fully open.
- Connect the power, press the ON/OFF button on the remote controller to turn the unit on.
 - Use the MODE button to select COOL, HEAT, AUTO and FAN to check if all the functions works well.
 - When the ambient temperature is too low (lower than 17°C), the unit cannot be controlled by the remote controller to run at cooling mode, manual operation can be taken. Manual operation is used only when the remote controller is disable or maintenance necessary.
 - Hold the panel sides and lift the panel up to an angle until it remains fixed with a clicking sound.
 - Press the Manual control button to select the AUTO or COOL, the unit will operate under Forced AUTO or COOL mode (see User Manual for details).
 - The test operation should last about 30 minutes.

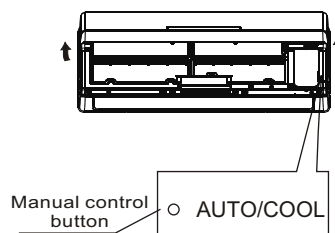

1 OUTDOOR INSTALLATION PRECAUTION

- Install the outdoor unit on a rigid base to prevent increasing noise level and vibration.
- Determine the air outlet direction where the discharged air is not blocked.
- In the case that the installation place is exposed to strong wind such as a seaside, make sure the fan operating properly by putting the unit lengthwise along the wall or using a dust or shield plates.
- Specially in windy area, install the unit to prevent the admission of wind. If need suspending installation, the installation bracket should accord with technique requirement in the installation bracket diagram. The installation wall should be solid brick, concrete or the same intensity construction, or actions to reinforce, damping supporting should be taken.
- The connection between bracket and wall, bracket and the air conditioner should be firm, stable and reliable.
- Be sure there is no obstacle which block radiating air.

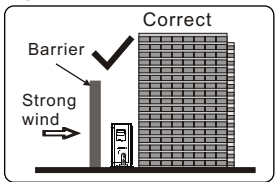
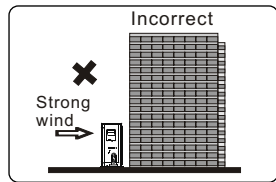

2 DRAIN JOINT INSTALLATION

NOTE: The drain joint is slightly different according to the different outdoor unit.

For the drain joint with the seal (Fig. A), first fit the seal onto the drain joint, then insert the drain joint into the base pan hole of outdoor unit, rotate 90° to securely assemble them. To install drain joint as shown in Fig. B, insert the drain joint into the base pan hole of outdoor unit until it remains fixed with a clicking sound. Connecting the drain joint with an extension drain hose (Locally purchased), in case of the water draining off the outdoor unit during the heating mode.

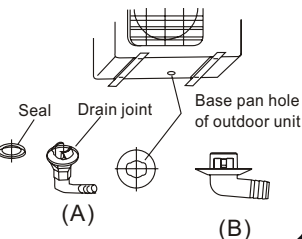

3 REFRIGERANT PIPE CONNECTION

Flaring

- Cut a pipe with a pipe cutter.
- Put flare nuts on pipe/tube having completed burr removal and flare the pipe.
- Firmly hold copper pipe in a die in the dimension shown in the table below.

Outer diam. (mm)	A (mm)	
	Max.	Min.
ϕ 6.35	1.3	0.7
ϕ 9.52	1.6	1.0
ϕ 12.7	1.8	1.0
ϕ 16	2.2	2.0

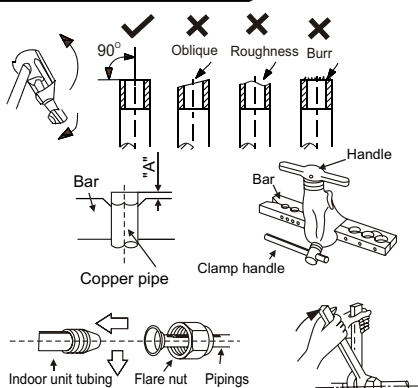

Tightening connection

- Align pipes to be connected.
- Sufficiently tighten the flare nut with fingers, and then tighten it with a spanner and torque wrench as shown.
- Excessive torque can break nut depending on installation conditions.

Outer diam.	Tightening torque (N.cm)	Additional tightening torque (N.cm)
ϕ 6.35mm	1500 (153kgf.cm)	1600 (163kgf.cm)
ϕ 9.52mm	2500 (255kgf.cm)	2600 (265kgf.cm)
ϕ 12.7mm	3500 (357kgf.cm)	3600 (367kgf.cm)
ϕ 16mm	4500 (459kgf.cm)	4700 (479kgf.cm)

ΕΓΧΕΙΡΙΔΙΟ ΕΓΚΑΤΑΣΤΑΣΗΣ ΓΙΑ ΚΛΙΜΑΤΙΣΤΙΚΗ ΜΟΝΑΔΑ

(Επιτοίχιες Μονάδες Διαιρούμενου Τύπου)

ΕΛΕΓΧΟΙ ΕΓΚΑΤΑΣΤΑΣΗΣ

- Παρακαλούμε πριν την λειτουργία της μονάδας διαβάστε προεκτικά αυτό το εγχειρίδιο, για να βεβαιωθείτε ότι έχει γίνει σωστή εγκατάσταση.
- Εάν το καλώδιο τροφοδοσίας είναι φθαρμένο, θα πρέπει να αντικατασταθεί από εξειδικευμένο προσωπικό.
- Η εγκατάσταση, συντήρηση και επισκευή αυτής της μονάδας θα πρέπει να γίνει από εξειδικευμένο τεχνικό.
- Αυτή η μονάδα δεν πρέπει να χρησιμοποιείται από άτομα με ειδικές ανάγκες, παιδιά ή άτομα με έλλειψη εμπειρίας και γνώσεων, εκτός αν επιβλέπονται από άτομα υπεύθυνα για την ασφάλειά τους.
- Τα παιδιά θα πρέπει να επιβλέπονται, ώστε να μην παίζουν με την μονάδα.
- Όλες οι εικόνες που παρουσιάζονται στο παρόν εγχειρίδιο είναι για επεξηγηματικούς λόγους μόνο. Το πραγματικό σχήμα μπορεί να διαφέρει.
- Ο σχεδιασμός και τα χαρακτηριστικά μπορεί να αλλάξουν χωρίς προειδοποίηση, για τη βελτίωση της μονάδας. Για λεπτομέρειες συμβουλευτείτε τον προμηθευτή σας.

ΟΔΗΓΙΕΣ ΑΣΦΑΛΕΙΑΣ

- Παρακαλούμε διαβάστε αυτές τις οδηγίες ασφαλείας πριν την εγκατάσταση.
- Ακολουθήστε όλες τις παρακάτω οδηγίες, είναι σημαντικές για την ασφάλειά σας.

	ΠΡΟΕΙΔΟΠΟΙΗΣΗ	Αυτό το σύμβολο υποδεικνύει την πιθανότητα σοβαρού τραυματισμού ή θανάτου.
	ΠΡΟΣΟΧΗ	Αυτό το σύμβολο υποδεικνύει την πιθανότητα τραυματισμού ή καταστροφή περιουσίας.

ΠΡΟΕΙΔΟΠΟΙΗΣΗ

- 1) Εγκαταστήστε τη μονάδα αυστηρά σύμφωνα με αυτές τις οδηγίες εγκατάστασης. Εάν η εγκατάσταση δεν έχει γίνει σωστά, μπορεί να προκληθεί διαρροή νερού, ηλεκτροπληξία ή πυρκαγιά.
- 2) Για την εγκατάσταση χρησιμοποιήστε αποκλειστικά τα συμπεριλαμβανόμενα και προδιαγραφόμενα εξαρτήματα, αλλιώς μπορεί να προκληθεί πτώση της μονάδας, διαρροή νερού, ηλεκτροπληξία ή πυρκαγιά.
- 3) Εγκαταστήστε τη μονάδα σε σταθερή βάση η οποία να μπορεί να αντέξει το βάρος της μονάδας. Εάν η βάση δεν είναι σταθερή ή η εγκατάσταση είναι ελλιπής, μπορεί να προκληθεί πτώση της μονάδας και να υπάρξει τραυματισμός.
- 4) Για τις ηλεκτρολογικές εργασίες θα πρέπει να ακολουθηθούν οι εθνικοί κανονισμοί και οι οδηγίες που περιγράφονται σε αυτό το εγχειρίδιο. Θα πρέπει να χρησιμοποιηθεί ξεχωριστό κύκλωμα. Εάν η χωρητικότητα του ηλεκτρικού κυκλώματος δεν είναι επαρκής ή αν είναι ελαττωματικό, μπορεί να προκληθεί ηλεκτροπληξία ή πυρκαγιά.
- 5) Χρησιμοποιήστε το προδιαγραφόμενο καλώδιο και συνδέστε το σφικτά στην επαφή έτσι ώστε να μην ασκείται εξωτερική πίεση στο τερματικό. Εάν η σύνδεση δεν είναι απολύτως σωστή θα προκληθεί υπερθέρμανση ή πυρκαγιά.
- 6) Θα πρέπει η διέλευση των καλωδίων να γίνει με τρόπο ώστε το κάλυμμα της πλακέτας να κλείνει. Εάν το κάλυμμα δεν τοποθετηθεί σωστά θα προκληθεί υπερθέρμανση στο σημείο σύνδεσης, ηλεκτροπληξία ή πυρκαγιά.
- 7) Κατά τη σύνδεση των σωληνώσεων, φροντίστε να μην εισέλθει αέρας, στο ψυκτικό κύκλωμα. Σε αντίθετη περίπτωση θα προκληθεί μείωση απόδοσης, υψηλή πίεση στο ψυκτικό κύκλωμα, έκρηξη και τραυματισμός.
- 8) Μην κάνετε μετατροπές στο μήκος του καλωδίου και μην χρησιμοποιείτε μπαλαντέζα. Μην χρησιμοποιείτε την ίδια πρίζα και για άλλες συσκευές. Μπορεί να προκληθεί ηλεκτροπληξία ή πυρκαγιά.

ΠΡΟΣΟΧΗ

- 1) Θα πρέπει να υπάρχει γείωση στη μονάδα και να τοποθετηθεί ρελέ διαφυγής. Εάν η γείωση δεν είναι σωστή μπορεί να προκληθεί ηλεκτροπληξία.
- 2) Μην τοποθετείτε τη μονάδα σε μέρος όπου μπορεί να προκληθεί διαρροή εύφλεκτου αερίου. Εάν υπάρχει μεγάλη διαρροή αερίου κοντά στη μονάδα μπορεί να προκληθεί πυρκαγιά.
- 3) Βεβαιωθείτε πως η σύνδεση του αγωγού αποστράγγισης έγινε σύμφωνα με τις οδηγίες εγκατάστασης. Εάν η απορροή των συμπυκνωμάτων δεν γίνεται σωστά μπορεί να εμφανιστεί διαρροή νερού από την εσωτερική μονάδα και να φθαρούν τα έπιπλα.

ΕΠΙΛΟΓΗ ΘΕΣΗΣ

Εσωτερική Μονάδα

- Δεν πρέπει κοντά στη μονάδα να υπάρχει κάποια πηγή θερμότητας ή αέρα.
- Δεν πρέπει να υπάρχουν εμπόδια στην κυκλοφορία του αέρα.
- Θα πρέπει να υπάρχει επαρκής κυκλοφορία του αέρα.
- Σε μέρος όπου μπορεί γίνεται εύκολα η απορροή συμπυκνωμάτων.
- Σε μέρος όπου αποφεύγεται ο θόρυβος.
- Μην τοποθετείτε τη μονάδα κοντά σε είσοδο πόρτας.
- Διατηρήστε τις αποστάσεις από την οροφή τους τοίχους και το δάπεδο σύμφωνα με τα βέλη.
- Δεν πρέπει να υπάρχει απευθείας ηλιακή ακτινοβολία. Εάν είναι αναπόφευκτο, πρέπει βρεθεί τρόπος προστασίας.

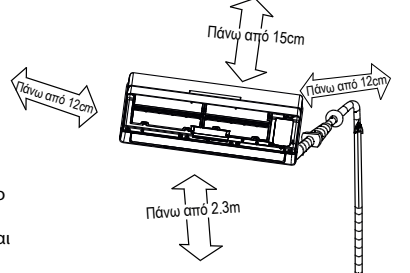

Εξωτερική Μονάδα

- Εάν υπάρχει στέγαστρο πάνω από τη μονάδα για προστασία από καιρικά φαινόμενα, βεβαιωθείτε πως δεν παρεμποδίζεται η έκλυση θερμότητας από την εξωτερική μονάδα.
- Δεν πρέπει κοντά να υπάρχει κάποιο ζώο ή φυτό που μπορεί να επηρεαστεί από τον ζεστό αέρα που αποβάλλεται.
- Διατηρήστε τις αποστάσεις από την οροφή, τους τοίχους, το πάτωμα ή άλλα εμπόδια σύμφωνα με τα βέλη.
- Μην τοποθετείτε αντικείμενα τα οποία μπορεί να εμποδίζουν τον αέρα που εξέρχεται από τη μονάδα.

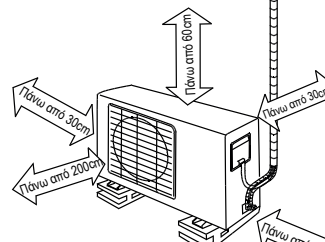

Εγκατάσταση της εξωτερικής μονάδας

- Στηρίξτε την εξωτερική μονάδα με βίδα και παξιμάδι Φ10 ή Φ8 σε στερεή βάση.
- ΣΗΜΕΙΩΣΗ:** Η εξωτερική μονάδα που έχετε αγοράσει μπορεί να έχει τις παρακάτω διαστάσεις. Εγκαταστήστε την εξωτερική μονάδα σύμφωνα με τις διαστάσεις που φαίνονται στον παρακάτω πίνακα:

Διαστάσεις εξωτερικής μονάδας σε mm (ΠxΥxΒ)		Διαστάσεις βάσης	
A (mm)	B (mm)	A (mm)	B (mm)
700x540x240	458	458	250
685x430x260	460	460	276
780x540x250	549	549	276
760x590x285	530	530	290
845x700x320	560	560	335
810x558x310	549	549	325
670x540x265	481	481	276

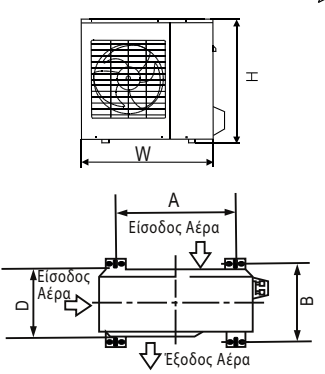

ΕΞΑΡΤΗΜΑΤΑ

A/A	Όνομασία Εξαρτήματος	Ποσότητα	
1	Βάση Εγκατάστασης	1	
2	Ούπα	5-8(ανάλογα το μοντέλο)	
3	Αυτοδιάρρητη Βίδα A ST3.9x25	5-8(ανάλογα το μοντέλο)	
4	Τάπα (Για μονάδες τύπου αντλίας θερμότητας)	1	
5	Σύνδεσμος αποστράγγισης (Για μοντέλα τύπου αντλίας θερμότητας)	1	
6	Σωλήνας σύνδεσης	Γραμμή υγρού	Φ6.35 Φ9.52
		Γραμμή αερίου	Φ9.52 Φ12.7 Φ16
7	Ασύρματο τηλεχειριστήριο	1	
8	Αυτοδιάρρητη Βίδα B ST2.9x10	2	
9	Βάση ασύρματου τηλεχειριστηρίου	1	
10	Φίλτρο καθαρισμού του αέρα (προαιρετικά για να τοποθετηθεί στο Φίλτρο)	1	

ΣΗΜΕΙΩΣΗ: Εκτός από τα παρεχόμενα εξαρτήματα, τα υπόλοιπα που θα χρειαστούν κατά την εγκατάσταση θα πρέπει να τα αγοράσετε.

1 ΕΓΚΑΤΑΣΤΑΣΗ ΤΗΣ ΒΑΣΗΣ

ΣΗΜΕΙΩΣΗ:

Βεβαιωθείτε ότι ο τοίχος είναι συμπαγής ώστε να αποφευχθούν δονήσεις.

Εγκατάσταση της Βάσης

1. Τοποθετήστε τη βάση οριζόντια στα δομικά στοιχεία του τοίχου αφήνοντας αποστάσεις γύρω από αυτή.
2. Εάν ο τοίχος είναι από τούβλα, τσιμέντο ή παρόμοιο υλικό, διανοίξτε 5 ή 8 οπές των 5mm. Εισάγετε τα κατάλληλα ούπα για τις αντίστοιχες βίδες.
3. Τοποθετήστε τη βάση στον τοίχο με 5 ή 8 βίδες τύπου "A".

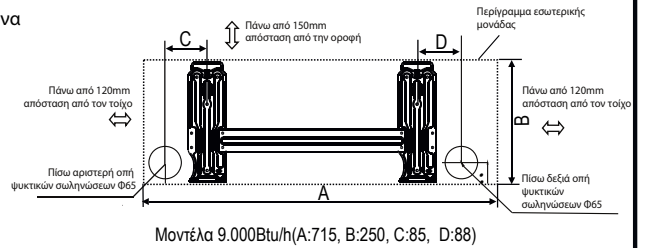

Μοντέλα 9.000Btu/h(A:715, B:250, C:85, D:88)

ΣΗΜΕΙΩΣΗ:

Τοποθετήστε τη βάση και διανοίξτε οπές στον τοίχο σύμφωνα με την δομή του τοίχου και τα αντίστοιχα σημεία στήριξης πάνω στη βάση. Η βάση που συνοδεύει τη μονάδα διαφέρει ανά μοντέλο. (Οι διαστάσεις είναι σε mm)

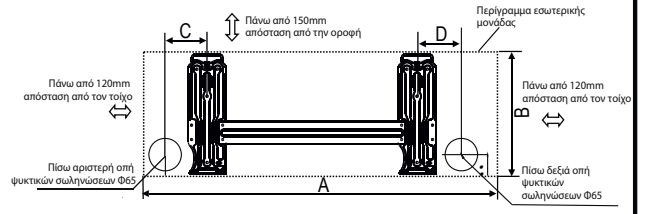

Μοντέλα 12.000Btu/h(A:800, B:275, C:100, D:95)

Σωστή οριοθέτηση της βάσης στήριξης

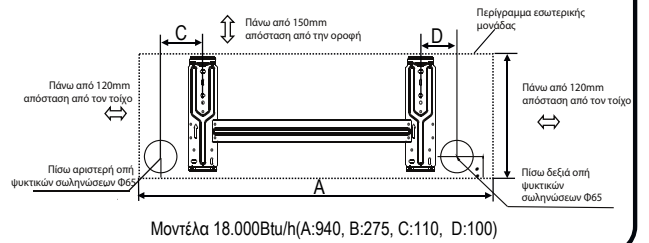
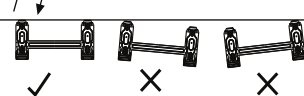

Μοντέλα 18.000Btu/h(A:940, B:275, C:110, D:100)

2 ΔΙΑΝΟΙΞΗ ΟΠΗΣ ΣΤΟΝ ΤΟΙΧΟ

1. Ορίστε τις θέσεις διανοίξης των οπών δεξιά και αριστερά από τη βάση στήριξης. Το κέντρο της οπής θα το υπολογίσετε μετρώντας την απόσταση όπως φαίνεται στο παραπάνω διάγραμμα.
2. Διανοίξτε την οπή για τις σωληνώσεις στη βάση με τρυπάνι Φ65.
3. Διανοίξτε την οπή για τις σωληνώσεις στη βάση είτε δεξιά είτε αριστερά με ελαφρά κλίση προς την εξωτερική πλευρά.
4. Φροντίστε η μονάδα να είναι προστατευμένη όταν τρυπάτε μεταλλικό πλέγμα, μεταλλική βάση ή κάτι παρόμοιο.

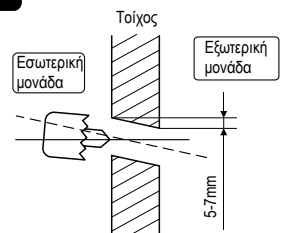

3 ΣΥΝΔΕΣΗ ΤΟΥ ΚΑΛΩΔΙΟΥ ΣΤΗΝ ΕΣΩΤΕΡΙΚΗ ΜΟΝΑΔΑ

Ηλεκτρική εργασία

Κανονισμοί ασφαλείας για την αρχική εγκατάσταση

1. Εάν υπάρχει σοβαρό πρόβλημα ασφαλείας με την παροχή ρεύματος, το τεχνικό προσωπικό θα πρέπει να αρνηθεί να προχωρήσει με την εγκατάσταση και να εξηγήσουν στον πελάτη πως δεν μπορεί να γίνει εγκατάσταση αν δεν λυθεί το πρόβλημα.
2. Η τάση δικτύου θα πρέπει να κυμαίνεται στο 90%-110% της βαθμονομημένης τάσης.
3. Στο κύκλωμα θα πρέπει να τοποθετηθεί διάταξη προστασίας υπέρτασης και ασφαλειοδιακόπτης με χωρητικότητα 1,5 φορά μεγαλύτερη από τη μέγιστη ένταση ρεύματος της μονάδας. Βεβαιωθείτε πως έχει γίνει σωστή γείωση.
4. Η μονάδα θα πρέπει να εγκατασταθεί σύμφωνα με τους εθνικούς κανονισμούς. Μην λειτουργείτε τη μονάδα σε χώρους όπως μπάνιο.
5. Οι μονάδες που έχουν εφεδρική αντίσταση πρέπει να βρίσκονται τουλάχιστον σε 1m απόσταση από εύφλεκτα υλικά.
6. Συνδέστε τα καλώδια σύμφωνα με τα ηλεκτρολογικά διαγράμματα που βρίσκονται στην εσωτερική και στην εξωτερική μονάδα.
7. Η συνδεσμολογία της μονάδας θα πρέπει να γίνεται σύμφωνα με τους εθνικούς κανονισμούς και από εξειδικευμένο προσωπικό.
8. Για την κλιματιστική μονάδα θα πρέπει να υπάρχει ειδικό ξεχωριστό κύκλωμα. Δείτε τον παρακάτω πίνακα για τις διατομές των καλωδίων και τις ασφάλειες:

Ελάχιστες διατομές αγωγών:

Ασφάλεια (A)	Διατομή καλωδίου (mm2)
>3 and ≤6	0.75
>6 and ≤10	1
>10 and ≤16	1.5
>16 and ≤25	2.5
>25 and ≤32	4
>32 and ≤40	6

ΣΗΜΕΙΩΣΗ:

- Η διατομή του παροχικού καλωδίου, του καλωδίου επικοινωνίας και η ασφάλεια προκύπτουν από την μέγιστη ένταση ρεύματος που φαίνεται στην πινακίδα χαρακτηριστικών η οποία βρίσκεται στο πλαϊνό πάνελ της μονάδας. Παρακαλούμε ανατρέξτε στην πινακίδα με τα χαρακτηριστικά πριν επιλέξετε διατομή καλωδίων και ασφάλεια.
- Η μονάδα έχει σχεδιαστεί με ειδική διάταξη υπερέντασης. Τα χαρακτηριστικά της ασφάλειας φαίνονται πάνω στην πλακέτα, όπως:

Σύνδεση του καλωδίου στην εσωτερική μονάδα

ΣΗΜΕΙΩΣΗ: Πριν εκτελέσετε οποιαδήποτε ηλεκτρική εργασία αποσυνδέστε την μονάδα από την παροχή ρεύματος.

1. Το καλώδιο σύνδεσης στην εσωτερική και εξωτερική μονάδα μπορεί να συνδεθεί χωρίς να αφαιρέσετε το μπροστινό πάνελ.
 2. Ο τύπος καλωδίου για την εσωτερική μονάδα είναι H05VV-F ή H05V2V2 και ο τύπος του καλωδίου τροφοδοσίας της εξωτερικής μονάδας καθώς και του καλωδίου ενδοεπικοινωνίας είναι H07RN-F.
 4. Βεβαιωθείτε πως τα χρώματα των καλωδίων καθώς και τα νούμερα των τερματικών επαφών της εσωτερικής μονάδας είναι ίδια με της εξωτερικής.
 5. Τυλίξτε με μονωτική ταινία τα καλώδια που δεν συνδέονται σε κάποια επαφή, ώστε να αποφευχθεί η επαφή τους με ηλεκτρικά μέρη. Ασφαλίστε το καλώδιο πάνω στην πλακέτα με σφικτήρα καλωδίου.
- ΣΗΜΕΙΩΣΗ:** Η διατομή του καλωδίου που συνδέεται στις επαφές L(1)/W, 1/1(L), 2(N) πρέπει να είναι επαρκής για την μέγιστη ένταση ρεύματος της μονάδας. Εάν αποτελεί μέρος MULTI συστήματος δεν χρειάζεται να συνδέσετε την επαφή L(1)/W.

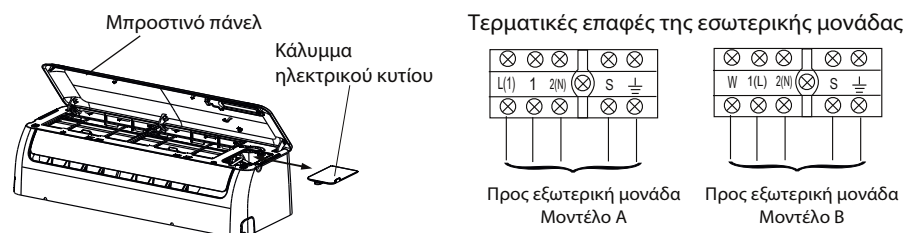

4 ΕΓΚΑΤΑΣΤΑΣΗ ΣΥΝΔΕΤΙΚΩΝ ΣΩΛΗΝΩΝ ΚΑΙ ΑΓΩΓΟΥ ΑΠΟΣΤΡΑΓΓΙΣΗΣ

Αποστράγγιση

1. Τοποθετήστε τον αγωγό αποστράγγισης με κλίση προς τα κάτω. Μην τοποθετείτε τον αγωγό αποστράγγισης όπως φαίνεται στις εικόνες.
2. Όταν συνδέτε αγωγό αποστράγγισης βεβαιωθείτε πως ο αγωγός αποστράγγισης είναι σφικτά συνδεδεμένος.

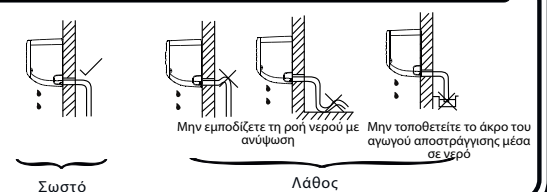

Εγκατάσταση σωλήνων σύνδεσης

- Για εγκατάσταση είτε δεξιά είτε αριστερά, αφαιρέστε την τάπα από το πλάιό πάνελ.
 - Για εγκατάσταση πίσω δεξιά ή πίσω αριστερά εγκαταστήστε τις σωληνώσεις όπως φαίνεται στην εικόνα.
- ΣΗΜΕΙΩΣΗ:** Η τοποθέτηση του αγωγού αποστράγγισης είναι τυποποιημένη και για τις 2 πλευρές. Η σύνδεση μπορεί να γίνει δεξιά, αριστερά ή και στις 2 πλευρές. Εάν επιλέξετε να γίνει και στις 2 πλευρές θα πρέπει να προμηθευτείτε και ακόμα 1 αγωγό αποστράγγισης, καθώς με τη συσκευασία παρέχεται μόνο 1. Εάν επιλέξετε μία από τις 2 πλευρές, βεβαιωθείτε πως η άλλη είναι σφραγισμένη.
- Για το μοντέλο των 9.000 Btu/h και 12.000Btu/h, εάν επιλέξετε η σύνδεση να γίνει στην αριστερή ή πίσω αριστερή πλευρά, επιλέξτε η σύνδεση του αγωγού αποστράγγισης να γίνει αριστερά.
- Η σύνδεση του αγωγού αποστράγγισης πρέπει να γίνει από εξειδικευμένο προσωπικό για την αποφυγή διαρροής νερού.
- Τυλίξτε τις σωληνώσεις, τα καλώδια και τον αγωγό αποστράγγισης με ταινία, όπως φαίνεται στην εικόνα δεξιά.

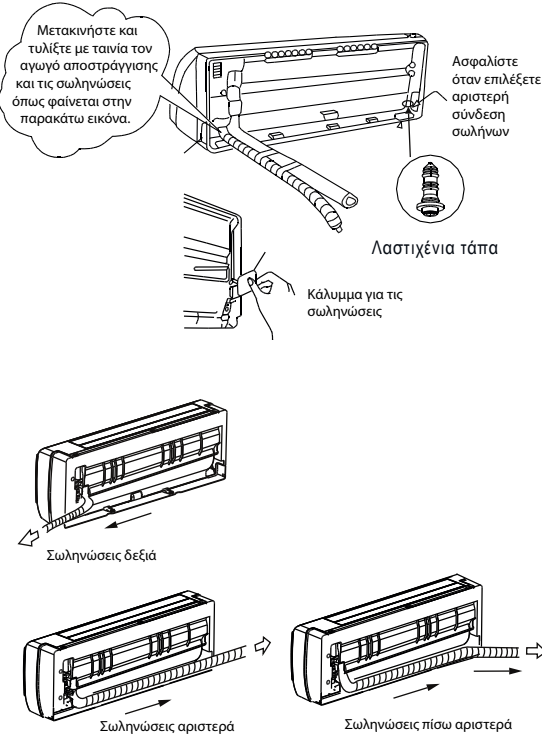

- Επειδή τα συμπυκνώματα συγκεντρώνονται σε λεκάνη συμπυκνωμάτων και μετά αποστραγγίζονται, μην τοποθετήσετε κάποιο αντικείμενο σε αυτή.

ΠΡΟΣΟΧΗ

- Συνδέστε πρώτα την εσωτερική μονάδα και μετά την εξωτερική.
- Φροντίστε οι σωληνώσεις να μην βγουν από το πίσω μέρος της μονάδας.
- Φροντίστε ο αγωγός αποστράγγισης να μην είναι χαλαρός.
- Θα πρέπει να τοποθετήσετε θερμομόνωση στον αγωγό αποστράγγισης.
- Βεβαιωθείτε πως ο αγωγός αποστράγγισης είναι στο χαμηλότερο σημείο της δέσμης, διότι αν είναι στο υψηλότερο σημείο μπορεί να προκληθεί διαρροή νερού από την εσωτερική μονάδα.
- Μην διασταυρώνετε και μην περιπλέξετε το καλώδιο τροφοδοσίας με οποιοδήποτε άλλο καλώδιο.

Εγκατάσταση εσωτερικής μονάδας

- Περάστε τις σωληνώσεις από την οπή στον τοίχο.
- Στερεώστε την εσωτερική μονάδα στο πάνω μέρος της βάσης. Βεβαιωθείτε πως τα άγκιστρα είναι σωστά τοποθετημένα πάνω στη βάση, κινώντας τη δεξιά και αριστερά.
- Οι σωληνώσεις μπορούν εύκολα να συνδεθούν ανασηκώνοντας λίγο τη μονάδα με ειδικό εργαλείο, το οποίο μπορείτε να το απομακρύνετε όταν ολοκληρώσετε τη σύνδεση.
- Πιέστε την κάτω δεξιά και κάτω αριστερή πλευρά της μονάδας στην βάση μέχρι τα άγκιστρα να μπουν στις αντίστοιχες κόγχες.

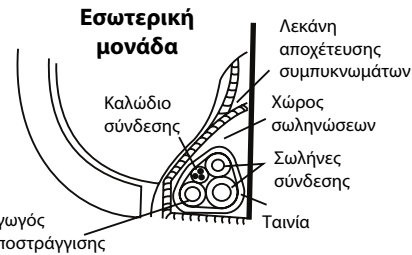

1 ΟΔΗΓΙΕΣ ΑΣΦΑΛΕΙΑΣ ΓΙΑ ΤΗΝ ΕΓΚΑΤΑΣΤΑΣΗ ΤΗΣ ΕΞΩΤΕΡΙΚΗΣ ΜΟΝΑΔΑΣ

- Εγκαταστήστε την εξωτερική μονάδα σε μια σταθερή και συμπαγή βάση για να αποφύγετε την αύξηση θορύβου και δονήσεων.
- Επιλέξτε μια θέση ώστε να μη εμποδίζεται η ροή εξερχόμενου αέρα.
- Εάν ο τόπος εγκατάστασης είναι εκτεθειμένος σε δυνατούς ανέμους, όπως κοντά σε ακτή, βεβαιωθείτε πως ο ανεμιστήρας λειτουργεί σωστά, τοποθετώντας την εξωτερική μονάδα παράλληλα στον τοίχο ή χρησιμοποιώντας ειδικά ελάσματα προστασίας από σκόνη.
- Ειδικά σε περιοχές με πολλούς ανέμους τοποθετήστε τη μονάδα με τέτοιο τρόπο ώστε να μην έρχεται σε απευθείας επαφή με τον αέρα. Εάν χρειαστεί η μονάδα, η εγκατάσταση της βάσης θα πρέπει να γίνει σύμφωνα με το αντίστοιχο διάγραμμα εγκατάστασης. Ο τοίχος θα πρέπει να είναι από τούβλο, τοιμητό ή παρόμοιο υλικό αλλιώς θα πρέπει να γίνουν ενέργειες ενίσχυσης.
- Η βάση θα πρέπει να είναι σταθερή και στιβαρή ώστε να είναι αξιόπιστη.
- Βεβαιωθείτε πως ο αποβαλλόμενος αέρας δεν παρεμποδίζεται

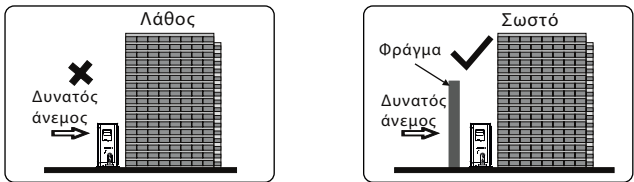

2 ΕΓΚΑΤΑΣΤΑΣΗ ΣΥΝΔΕΣΜΟΥ ΑΠΟΣΤΡΑΓΓΙΣΗΣ

- ΣΗΜΕΙΩΣΗ:** Ο σύνδεσμος αποστράγγισης διαφέρει ανάλογα την εξωτερική μονάδα.
- Όταν πρόκειται για σύνδεσμο με ασφάλεια (Εικ. Α), τοποθετήστε πρώτα την ασφάλεια πάνω στον σύνδεσμο, έπειτα εισάγετε τον σύνδεσμο στην οπή που υπάρχει στο κάτω μέρος της εξωτερικής μονάδας και στρέψτε τον 90 μοίρες.
- Για τα τοποθετήστε ένα σύνδεσμο αποστράγγισης όπως φαίνεται στην Εικ. Β, εισάγετε τον σύνδεσμο στην οπή στο κάτω μέρος της εξωτερικής μονάδας μέχρι να ακούσετε έναν ήχο "κλικ". Μπορείτε να συνδέσετε έναν αγωγό αποστράγγισης, για την απορροή συμπυκνωμάτων από την εξωτερική μονάδα όταν λειτουργεί σε θέρμανση.

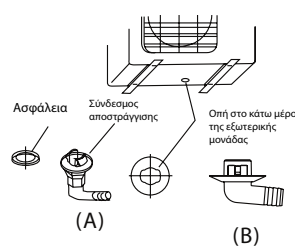

3 ΣΥΝΔΕΣΗ ΨΥΚΤΙΚΩΝ ΣΩΛΗΝΩΝ

- Εκχειλωση**
- Κόψτε ένα σωλήνα με ειδικό εργαλείο κοπής
 - Τοποθετήστε τα εκχειλιωτικά παξιμάδια στον σωλήνα έχοντας απομακρύνει τα γρέζια και εκχειλώστε τον σωλήνα
 - Κρατήστε σταθερά τον χαλκοσωλήνα σε ένα βιδολόγο με τις διαστάσεις που φαίνονται στον παρακάτω πίνακα.

Εξωτερική διάμετρος(mm)	A(mm)	
	Μέγιστο	Ελάχιστο
φ 6.35	1.3	0.7
φ 9.52	1.6	1.0
φ 12.7	1.8	1.0
φ 16	2.2	2.0

Σύσφιξη σύνδεσης

- Ευθυγραμμίστε τις σωλήνες που θα συνδέσετε
- Σφίξτε τα παξιμάδια αρχικά χειροκίνητα και έπειτα με ροπόκλειδο και γαλλικό κλειδί.
- Υπερβολική ροπή μπορεί να προκαλέσει ράγισμα στο παξιμάδι ανάλογα τις συνθήκες εγκατάστασης

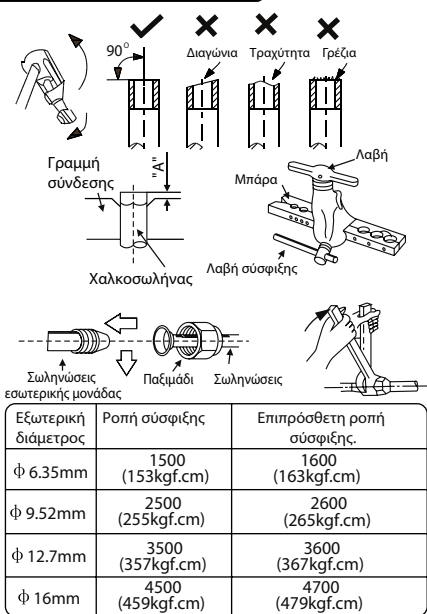

4 ΣΥΝΔΕΣΗ ΚΑΛΩΔΙΟΥ ΣΤΗΝ ΕΞΩΤΕΡΙΚΗ ΜΟΝΑΔΑ

- Αφαιρέστε το κάλυμμα από την πλακέτα σύνδεσης της εξωτερικής μονάδας χαλαρώνοντας τη βίδα.
- Συνδέστε τα καλώδια στις επαφές σύμφωνα με τα νούμερα που έχουν.
- Ασφαλίστε το καλώδιο πάνω στην πλακέτα με σφιγκτήρα καλωδίου
- Για την αποφυγή εισόδου νερού, σχηματίστε ένα βρόγχο με τα καλώδια όπως φαίνεται στο διάγραμμα εγκατάστασης στην εσωτερική και εξωτερική μονάδα.
- Τυλίξτε τα καλώδια που δεν χρησιμοποιούνται με μονωτική ταινία και βεβαιωθείτε πως δεν έρχονται σε επαφή με ηλεκτρικά ή μεταλλικά μέρη.

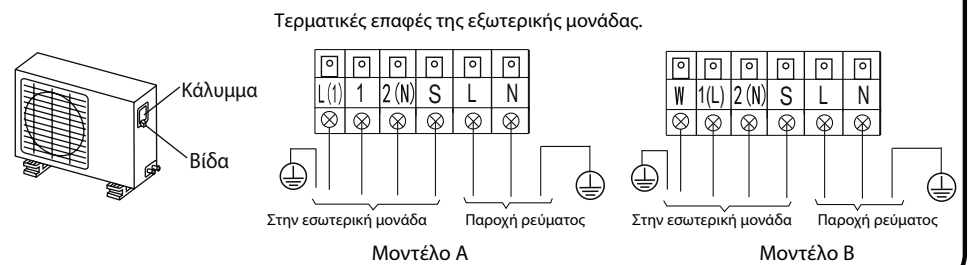

5 ΚΕΝΟ ΚΑΙ ΔΟΚΙΜΑΣΤΙΚΗ ΛΕΙΤΟΥΡΓΙΑ

ΣΗΜΕΙΩΣΗ: Το μήκος των ψυκτικών σωληνώσεων επηρεάζουν την απόδοση της μονάδας. Η ονομαστική απόδοση έχει υπολογιστεί για μήκος σωληνώσεων 5m.

1. Κενό

- Η εσωτερική μονάδα καθώς και οι σωληνώσεις θα πρέπει να ελεγχθούν για διαρροές και θα πρέπει να γίνει κενό ώστε να απομακρυνθούν τυχόν σωματίδια και αέρας από το ψυκτικό κύκλωμα.
- Βεβαιωθείτε πως οι σωληνώσεις έχουν συνδεθεί σωστά και πως έχει ολοκληρωθεί ο έλεγχος των καλωδίων.
- Μήκος σωληνώσεων και πλήρωση ψυκτικού υγρού:

Μήκος σωληνώσεων	Μεθοδολογία κενού	Επιπλέον πλήρωση ψυκτικού υγρού	
Κάτω από 5m	Χρησιμοποιήστε αντλία κενού	—	
Πάνω από 5m	Χρησιμοποιήστε αντλία κενού	Γραμμή υγρού: Φ6.35mm (1/4") R22:(Μήκος σωληνώσεων-5)x30g/m R410A:(Μήκος σωληνώσεων-5)x20g/m	Γραμμή υγρού: Φ9.52mm (3/8") R22:(Μήκος σωληνώσεων-5)x60g/m R410A:(Μήκος σωληνώσεων-5)x40g/m

- Για το μοντέλο με R410A ψυκτικό υγρό, βεβαιωθείτε πως το ψυκτικό υγρό που προστίθεται είναι σε υγρή μορφή
- Όταν μετακινήσετε τη μονάδα σε άλλο μέρος να κάνετε κενό με αντλία κενού

ΠΡΟΣΟΧΗ

- Ανοίξτε το στέλεχος της βαλβίδας μέχρι να τερματίσει. Μην προσπαθήσετε να το ανοίξετε περισσότερο
- Σφίξτε το κάλυμμα του στελέχους της βαλβίδας με γαλλικό κλειδί.
- Για την ροπή σύσφιξης δείτε τον αντίστοιχο πίνακα.

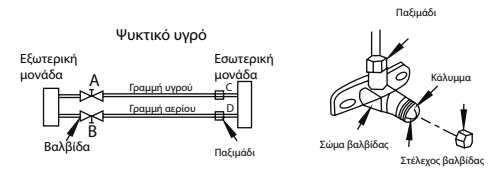

2. Χρήση της Αντλίας Κενού

- Σφίξτε τα παξιμάδια Α,Β,Γ,Δ. Συνδέστε το σωλήνα φόρτισης της βαλβίδας πολλαπλής στο άκρο φόρτισης της βαλβίδας χαμηλής πίεσης.
- Συνδέστε τη σωλήνα φόρτισης με την αντλία κενού.
- Ανοίξτε εντελώς τη λαβή της βαλβίδας πολλαπλής Lo.
- Λειτουργήστε την αντλία κενού για να γίνει εκκένωση. Αρχικά χαλαρώστε ελαφρώς η διαδικασία, κλείστε το παξιμάδι συναρρογής της βαλβίδας χαμηλής πίεσης για να ελέγξετε ότι εισέρχεται αέρας στο εσωτερικό. (Αλλάζει ο ήχος της αντλίας κενού και η ένδειξη στο πολύμετρο γίνεται 0 αντί για μείον)
- Αφού ολοκληρωθεί η διαδικασία, κλείστε τη λαβή Lo και σταματήστε τη λειτουργία της αντλίας κενού.
- Η εκκένωση θα πρέπει να γίνει για τουλάχιστον 15 λεπτά και ελέγξτε πως η ένδειξη στο πολύμετρο είναι -76cmHg(-1.0x105Pa).
- Στέψτε το στέλεχος της βαλβίδας Β για περίπου 45 μοίρες με τη φορά τη ρολογιού για 6-7 δευτερόλεπτα από τη στιγμή που άρχισε να εξέρχεται αέριο. Έπειτα σφίξτε πάλι το παξιμάδι. Βεβαιωθείτε πως η πίεση που εμφανίζεται στο μανόμετρο είναι λίγο υψηλότερη από την ατμοσφαιρική.
- Απομακρύνετε το σωλήνα φόρτισης από το άκρο φόρτισης της βαλβίδας χαμηλής πίεσης.
- Ανοίξτε εντελώς τις βαλβίδες Β και Α
- Σφίξτε το καπάκι της βαλβίδας χαμηλής πίεσης.

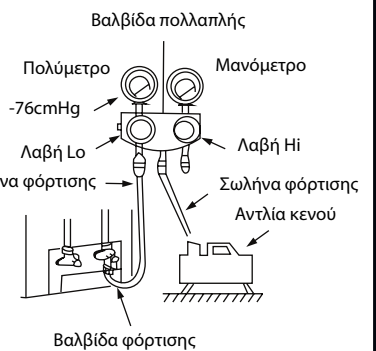

3. Έλεγχος ασφαλείας και διαρροών

- Μέθοδος με σαπούνι και νερό: Αλοιψίστε με σαπουνόδιαλύμα ή ουδέτερο απορρυπαντικό τις συνδέσεις στην εσωτερική και εξωτερική μονάδα χρησιμοποιώντας μια μαλακή βούρτσα. Εάν εμφανιστούν φυσαλίδες σημαίνει ότι υπάρχει διαρροή.
 - Ανιχνευτής διαρροών: Χρησιμοποιήστε ανιχνευτή διαρροών
- ΠΡΟΣΟΧΗ**
Α: Lo βαλβίδα (χαμηλής). Β: Hi βαλβίδα (υψηλής)
Γ και Δ είναι τα άκρα των συνδέσεων της εσωτερικής μονάδας

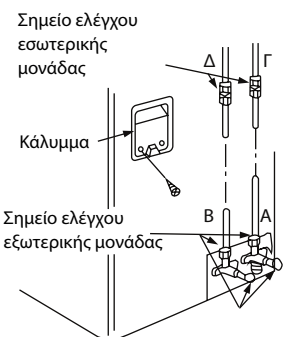

4. Δοκιμαστική Λειτουργία

Μετά τον έλεγχο για διαρροές στις συνδέσεις και τον έλεγχο στην συνδεσμολογία, να προχωρήσετε σε μια δοκιμαστική λειτουργία.

- Ελέγξτε ότι όλες οι συνδέσεις σωληνώσεων και καλωδίων έχουν γίνει σωστά
- Ελέγξτε ότι οι βαλβίδες αερίου και υγρού είναι ανοιχτές.
- Συνδέστε την παροχή ρεύματος και πιέστε το πλήκτρο ON/OFF στο ασύρματο τηλεχειριστήριο για να ενεργοποιηθεί η λειτουργία της μονάδας.
- Με το πλήκτρο MODE επιλέξτε COOL (ΨΥΞΗ), HEAT (ΘΕΡΜΑΝΣΗ), AUTO (ΑΥΤΟΜΑΤΟ) και FAN (ΑΝΕΜΙΣΤΗΡΑΣ) για να ελέγξετε ότι όλες οι λειτουργίες λειτουργούν σωστά.
- Όταν η εξωτερική θερμοκρασία περιβάλλοντος είναι πολλή χαμηλή (κάτω από 17C), δεν μπορεί να δοθεί εντολή στη μονάδα να λειτουργήσει σε ψύξη από το τηλεχειριστήριο, μόνο χειροκίνητα. Η χειροκίνητη λειτουργία θα πρέπει να χρησιμοποιείται μόνο όταν το ασύρματο τηλεχειριστήριο δεν λειτουργεί ή όταν γίνονται εργασίες συντήρησης.
- Κρατήστε το πάνελ και από τις 2 πλευρές και σηκώστε το μέχρι να ακούσετε έναν ήχο "κλικ".
- Εάν πιέσετε το πλήκτρο MANUAL για να επιλέξετε λειτουργία AUTO ή COOL, η μονάδα θα λειτουργήσει σε αναγκαστική αυτόματη λειτουργία ή ψύξη (δείτε το εγχειρίδιο χρήσης για λεπτομέριες).
- Η δοκιμαστική λειτουργία θα πρέπει να διαρκέσει περίπου 30 λεπτά.

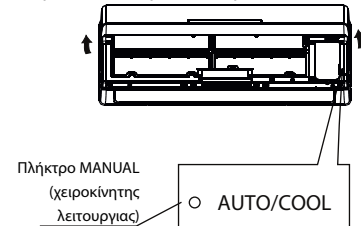

MANUALUL DE INSTALARE PENTRU APARAT AER CONDIȚIONAT DE CAMERĂ (Tip Split, montare pe perete)

MĂSURI DE SIGURANȚĂ PRIVIND INSTALAREA

- Vă rugăm să citiți acest manual de instalare cu atenție înainte de a utiliza aparatul pentru a asigura instalarea corectă
- În cazul în care cablul de alimentare este deteriorat, înlocuirea se efectuează numai de personal autorizat
- Lucrările de instalare trebuie să fie efectuate numai de personal autorizat în conformitate cu standardele naționale de cablare
- Contactați un tehnician de service autorizat pentru repararea, întreținerea și instalarea acestei unități.
- Acest aparat nu este destinat utilizării de către persoane (inclusiv copii) cu deficiențe fizice, senzoriale sau mentale, sau lipsite de experiență și cunoștințe, cu excepția cazului în care acestea au fost supravegheate sau instruite cu privire la utilizarea aparatului de către persoane responsabile pentru siguranța lor
- Copiii trebuie supravegheați pentru a se asigura că nu se joacă cu aparatul.
- Toate imaginile din instrucțiuni sunt doar pentru scopuri de prezentare. Forma actuală ar trebui să prevaleze.
- Designul și specificațiile pot fi modificate fără notificare prealabilă pentru îmbunătățirea produselor.
- Consultați-vă cu agenția de vânzări sau producătorul pentru detalii.

MĂSURI DE SIGURANȚĂ

- Vă rugăm să citiți cu atenție aceste măsuri de siguranță înainte de instalare.
- Asigurați-vă de respectarea tuturor măsurilor de precauție de mai jos; toate sunt importante pentru asigurarea securității.

	AVERTIZARE	Acest simbol indică posibilitatea de moarte sau rănire gravă.
	ATENȚIE	Acest simbol indică posibilitatea de rănire sau daune materiale.

AVERTIZARE

- Instalați în strictă conformitate cu aceste instrucțiuni de instalare. Dacă instalarea este defectuoasă, aceasta va duce la scurgeri de apă, șoc electric sau incendiu.
- Utilizați doar accesoriile, piesele și componentele specificate pentru instalare. În caz contrar, aceasta va cauza ca unitatea să cadă, apariția unor scurgeri de apă, electrocutare sau incendiu.
- Instalați la o locație puternică și fermă, care este capabilă să reziste la greutatea setului. Dacă locul ales nu este suficient de rezistent sau instalarea nu este făcută în mod corespunzător, setul va cădea și cauza leziuni.
- Pentru lucrul cu cablurile electrice, respectați standardul local național pentru cabluri, reglementările în domeniu și aceste instrucțiuni de instalare. Trebuie utilizat un circuit independent. În cazul în care capacitatea de circuit electric nu este suficientă sau defectă, aceasta va provoca șoc electric sau incendiu.
- Utilizați cablul specificat și conectați strâns, fixați cablul astfel încât nici o forță externă nu va acționa pe terminal. În cazul în care conexiunea nu este perfectă, aceasta va cauza supra-încălzirea cablului și conexiunea va putea provoca incendiu.
- Cablarea de rutare trebuie să fie aranjată corespunzător, astfel încât acoperirea panoului de control este fixată corespunzător. În cazul în care placa de control nu este fixată perfect, se va supraîncălzi la punctul de conectare provocând incendiu sau există risc de electrocutare.
- La efectuarea conexiunii de conducte, aveți grijă să nu lăsați să pătrundă alte substanțe, în afară de cel specificat ca refrigerant în ciclul de refrigerare. Altfel, aceasta va cauza scăderea capacității, presiune anormală în ciclul de refrigerare, explozie și accidentări.
- Nu modificați lungimea cablului de alimentare sau utilizarea de cablu prelungitor. Folosiți pentru alimentare o priză unică, nu alimentați împreună cu alte aparate electrice. În caz contrar, aceasta va provoca un incendiu sau șoc electric.

ATENȚIE

- Acest echipament trebuie să fie legat cu împământare. În caz contrar pot apărea șocuri electrice.
- Nu instalați unitatea în locuri unde pot apărea scurgeri de gaze inflamabile. Scurgerile de gaze acumulate în jurul unității, pot provoca incendiu.
- Efectuarea de conducte de drenaj așa cum se menționează în instrucțiunile de instalare. Dacă drenajul nu este perfect, apa poate intra în cameră și deteriora mobilă.

ALEGEREA CELEI MAI BUNE LOCAȚII

Unitatea interioară

- Nu ar trebui să fie nici o sursă de căldură sau abur în apropierea aparatului.
- Nu ar trebui să existe obstacole care blochează circulația aerului.
- Un loc unde circulația aerului în cameră este bună.
- Un loc unde drenajul poate fi foarte ușor de făcut.
- Un loc unde prevenirea zgomotului este luată în considerare.
- Nu instalați aparatul în apropierea ușilor de acces.
- Asigurați-vă că spațiile indicate de săgeți de la perete, tavan, gard sau alte obstacole sunt respectate.
- Feriți de lumina soarelui. Dacă acest lucru este inevitabil, prevenirea luminii soarelui trebuie să fie luată în considerare.

Unitatea exterioară

- În cazul în care în jurul unității exterioare există o construcție pentru a o feri de razele soarelui sau de ploaie, asigurați-vă că aceasta nu obstrucționează căldura de la condensator.
- Nu ar trebui să fie nici un animal sau plantă care ar putea fi afectate de aerul cald evacuat.
- Păstrați spațiile indicate de săgeată de la perete, tavan, gard sau alte obstacole.
- Nu puneți obstacole care pot cauza un scurt-circuit al aerului evacuat.

Așezarea unității exterioare

- Ancorați unitatea exterioară cu un șurub și piuliță de 10 sau de 8 strâns și orizontal pe un beton sau perete rigid
NOTĂ: Unitatea exterioară poate fi ca una din tabel. Instalați unitatea exterioară în funcție de dimensiunile din tabel:

Dimensiuni unitate exterioară (LxIxA)	Dimensiuni montare	
	A (mm)	B (mm)
700x540x240	458	250
685x430x260	460	276
780x540x250	549	276
760x590x285	530	290
845x700x320	560	335
810x558x310	549	325
670x540x265	481	276

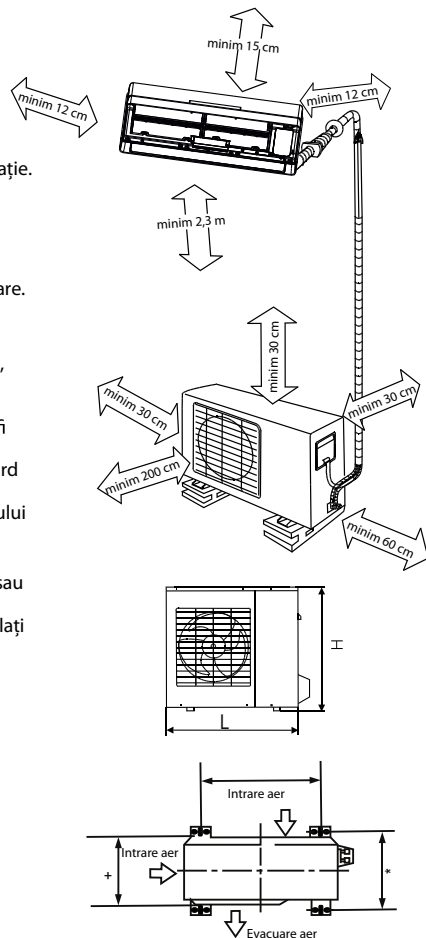

ACCESORII

Nr.	Denumire accesoriu	Cantitate		
1	Placă de instalare	1		
2	Clip Anchor	5-8 (în funcție de model)		
3	Șurub autofiletant A ST3.0x25	5-8 (în funcție de model)		
4	Sigiliu (numai pentru modelele de răcire și de încălzire)	1		
5	Scurgere comună (numai pentru modelele de răcire și de încălzire)	1		
6	Teava de legătură	Lichid	Φ6.35	Piese de schimb ce trebuie cumpărate separat. Dimensiunea conductei diferă de la aparat la aparat. Consultați tehnicianul pentru alegerea corectă a conductei.
		Gaz	Φ9.52	
			Φ9.52	
			Φ12.7	
Φ16				
7	Telecomandă	1		
8	Șurub autofiletant B ST2.9x10	2		
9	Suport telecomandă	1		
10	Filtru de împropățare a aerului (folosit pentru a fi instalat pe filtrul de aer)	1		

NOTĂ: Cu excepția pieselor de mai sus, celelalte părți necesare în timpul instalării trebuie cumpărate separat.

1 INSTALAREA UNITĂȚII INTERIOARE

NOTĂ:

Peretele de montare este suficient de puternic și solid pentru a preveni vibrațiile.

Instalare Placă de montaj

- Montați placa de instalare orizontal pe părți structurale ale peretelui cu spații în jurul plăcii de instalare.
- În cazul în care peretele este din cărămidă, beton sau materiale asemănătoare, forțați orificii cu diametrul de 5 sau 8 mm. Introduceți ancora pentru șuruburi de fixare adecvate.
- Montați placa de montaj pe perete cu șuruburi de 5 sau 8 de tip A.

NOTĂ:

Montați placa de instalare prin foraj găuri în perete în funcție de structura peretelui și de punctele de montare de pe placă.
Placa de instalare furnizată diferă de la aparat la aparat
(Dimensiunile sunt în mm, doar dacă nu este altfel specificat)

Instalarea corectă a plăcilor.

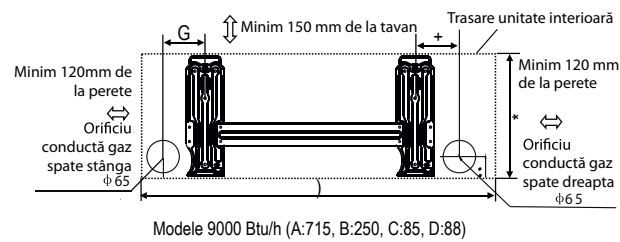
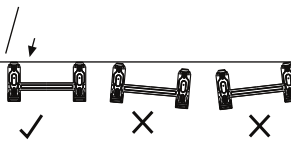

Modele 9000 Btu/h (A:715, B:250, C:85, D:88)

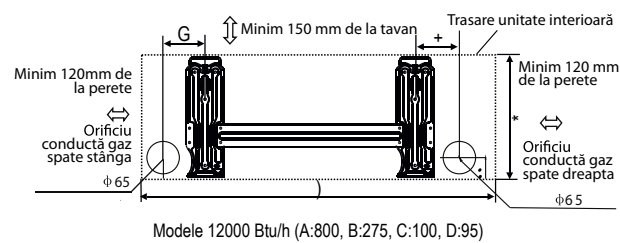

Modele 12000 Btu/h (A:800, B:275, C:100, D:95)

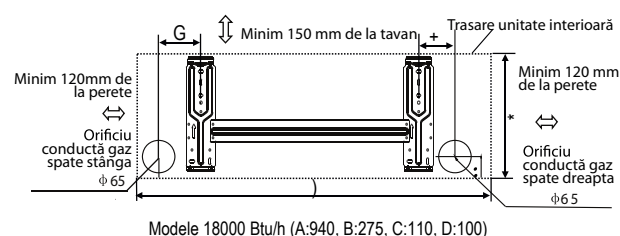

Modele 18000 Btu/h (A:940, B:275, C:110, D:100)

2 PERFORARE PERETE

- Determinarea poziției găurii în conformitate cu stânga și cu dreapta plăcii de instalare. Se obține centrul găurii prin măsurarea distanței așa cum se arată în diagrama de mai sus.
- Perforați o gaură de diametru 65 mm.
- Mașina de găurit trebuie să fie ușor înclinată spre partea exterioară.
- La întotdeauna măsuri pentru a proteja conducta atunci când găuriți metale ori plăci de metal.

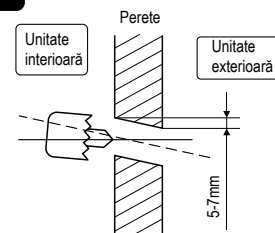

3 CONECTAREA CABLURILOR LA UNITATEA INTERIOARĂ

Lucrări electrotehnice

Reglementările electrice de siguranță pentru instalarea inițială

- Dacă există o problemă serioasă de securitate cu privire la sursa de alimentare, tehnicienii ar trebui să refuze instalarea aparatului de aer condiționat și să explice clientului că problema trebuie rezolvată.
- Tensiunea de alimentare trebuie să fie în intervalul de la 90% ~ 110% din tensiunea nominală.
- Protecția la supratensiune și întrerupătorul principal, cu o capacitate de 1,5 ori față de maximul unității ar trebui să fie instalat în circuitul de alimentare. Asigurați-vă că aparatul de aer condiționat este bine împământat
- Aparatul trebuie să fie instalat în conformitate cu reglementările naționale de cablare. Nu folosiți aerul dvs. condiționat într-o cameră umedă, cum ar fi o baie sau spălătorie.
- Un dispozitiv de deconectare multi-poli, care are cel puțin 3 mm în toți polii, și au o scurgere actuală ce poate depăși 10 mA, dispozitivul de curent rezidual (RCD) cu o funcționare reziduală nominală de 30mA maxim, și deconectarea trebuie să fie incorporată în cablajul fix, în conformitate cu normele de cablare.
- Pentru unitatea care adoptă încălzitor electric auxiliar, să se păstreze cel puțin 1 metru distanță de cea mai apropiată sursă de materiale inflamabile
- Conectați cablurile în conformitate cu diagrama de Conexiune electrică situată pe panoul unităților
- Toate cablajele trebuie să respecte codurile electrice locale și naționale și să fie instalate de către electricieni calificați
- Să fie disponibil un circuit de ramură individual și singur folosit numai pentru acest aparat de aer condiționat. Consultați următorul tabel pentru dimensiuni de sârmă sugerate și specificații siguranțe:

Curent nominal de aparat (A)	Domeniul nominal al secțiunii transversale (mm ²)
>3 și ≤6	0,75
>6 și ≤10	1
>10 și ≤16	1,5
>16 și ≤25	2,5
>25 și ≤32	4
>32 și ≤40	6

NOTĂ:

- Nominala secțiunii transversale a cablului și curentul de siguranță sau întrerupătorul sunt determinate de către curentul maxim indicat pe plăcuța care este situată pe latura panoului unității. Vă rugăm să consultați plăcuța înainte de a selecta dimensiunea de sârmă, siguranțe sau întrerupător.
- Regulatorul de aer condiționat proiectat cu o funcție de protecție în condiții anormale, caietul de sarcini al siguranței s-au imprimat pe placa de circuit, cum ar fi: T3.15A/250VAC, T5A/250VAC, etc.

Conectarea cablului la unitatea internă

NOTĂ: Înainte de a efectua orice lucrare electrică, opriți alimentarea principală a sistemului

- Atât la interior cât la și exterior, cablul de conectare poate fi conectat fără a scoate grila frontală.
- Cablul de alimentare la interior este de tipul H05VV-F sau H05V2V2-F, iar cel exterior este H07RN-F.
- Ridicați panoul unității de interior în sus, scoateți capacul cutiei electrice prin slăbirea șurubului.
- Asigurați-vă că culoarea de fire de la unități corespund.
- Înfășurați aceste cabluri cu benzi de izolare, astfel încât acestea să nu atingă alte componente electrice. Fixați cablul de pe panoul de control cu clema cordon.

NOTĂ: Dacă este folosit ca unitate MONO, pentru standby, aria secțiunii transversale a cablului conectat pentru L (1) / W, 1/1 (L), 2 (N) trebuie să fie suficientă pentru curentul maxim din sistem. Curentul maxim de sistem este egal cu suma de la unitatea interioară și curentul nominal al unității exterioare. Dacă este folosit ca unitate MULTI, L (1) / W de la blocul terminal nu trebuie să fie conectat

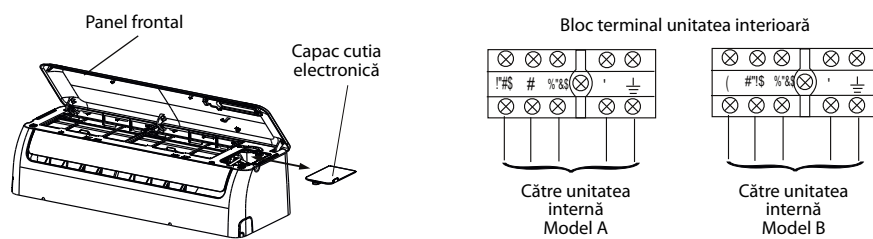

4 CONECTAREA CONDUCTELOR ȘI A DRENAJULUI

Drenaj

- Rulați în pantă furtunul de evacuare în jos. Nu instalați furtunul de evacuare așa cum este ilustrat în figură.
- La conectarea furtunului de evacuare de extensie, izolați partea de conectare de extindere a furtunului de evacuare cu o țevă de scut, nu lăsați scurgerea furtunului să fie moale.

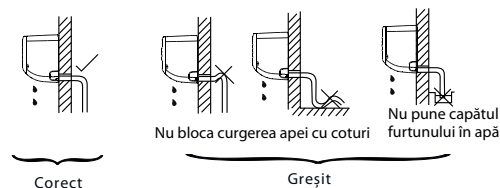

Instalarea și conectarea conductelor

1. Pentru tubulatura stânga și dreapta, scoateți capacul de conducte din panoul lateral.
2. Pentru partea stângă sau dreaptă, instalați așa cum este prezentat în imagini.

NOTĂ: Ambele părți ale structurii de drenaj sunt standard. Pentru ambele părți structura de drenaj poate fi de dreapta, la stânga sau la ambele părți. În cazul în care alegerea de ambele părți, este nevoie de un alt furtun de golire propriu-zis, deoarece există o singură scurgere. În cazul în care alegeți o conexiune de drenaj lateral, asigurați-vă că este bine realizată conectarea de scurgere. Pentru modelele 9k/12k, în cazul în care alegerea stânga sau stânga-spate, vă rugăm să alegeți partea stângă pentru conexiunea de drenaj. Conectarea furtunului de evacuare ar trebui să fie făcut de către instalator calificat, pentru a evita scurgeri de apă.

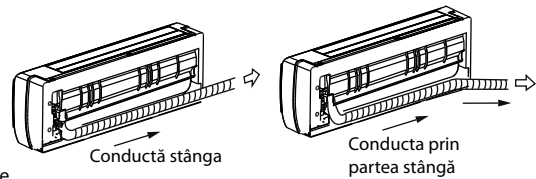
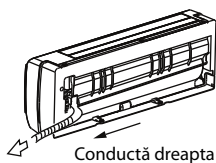
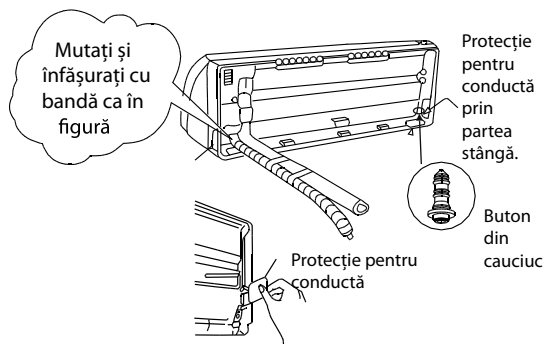

- Deoarece apa condensată din spatele Unității interioare se adună în tava de condens, nu puneți nimic altceva în cutie

ATENȚIE

- Conectați unitatea interioară și apoi unitatea exterioară.
- Nu permiteți tubulaturii să iasă din partea din spate a unității interioare.
- Aveți grijă să nu permiteți strângerea furtunului de evacuare.
- Izolația termică ar trebui să fie făcută și pentru prelungirea furtunului de evacuare din unitatea interioară.
- Asigurați-vă că furtunul de evacuare este situat la cea mai mică parte a mănunchiului. Localizarea la partea superioară poate provoca scurgere până la inundarea unității.
- Nu se încrucișează cablul de alimentare cu orice alte cabluri.

Instalare unitate interioară

1. Treceți țevile prin gaura din perete.
2. Prindeți unitatea interioară pe partea superioară a plăcii de instalare (Activați unitatea interioară cu marginea superioară a plăcii de instalare). Asigurați cărligele să fie așezate în mod corespunzător
3. Conductele pot fi făcute cu ușurință prin ridicarea unității cu un material de amortizare poziționat între unitatea interioară și perete. Eliminați materialul la finalizare
4. Apăsați partea stângă inferioară și partea dreaptă a unității pe placa de montaj până când cărligele se prind.

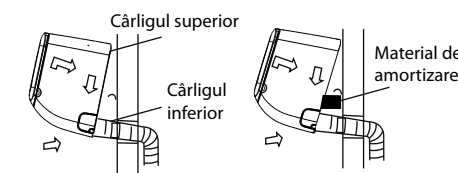
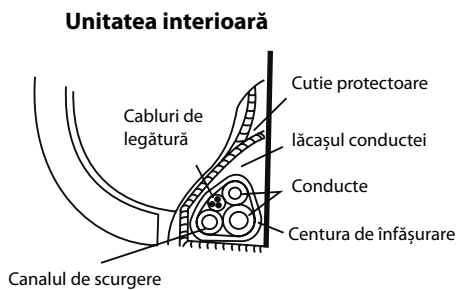

4 CONECTAREA CABLURILOR LA UNITATEA EXTERIOARĂ

1. Scoateți capacul plăcii de control electric de la unitatea exterioară prin slăbirea șurubului.
2. Conectați cablurile la terminalele identificate cu numerele lor de potrivire respective pe blocul de conexiuni de unități interioare și exterioare.
3. Fixați cablul de pe panoul de control cu clema cordon.
4. Pentru a preveni pătrunderea apei, formați o buclă de cablu cum este ilustrat în diagrama unităților, internă și externă.
5. Izolați cablurile neutilizate (conductori) cu PVC-bandă, astfel încât acestea să nu se atingă de nici un cablu electric sau piese metalice.

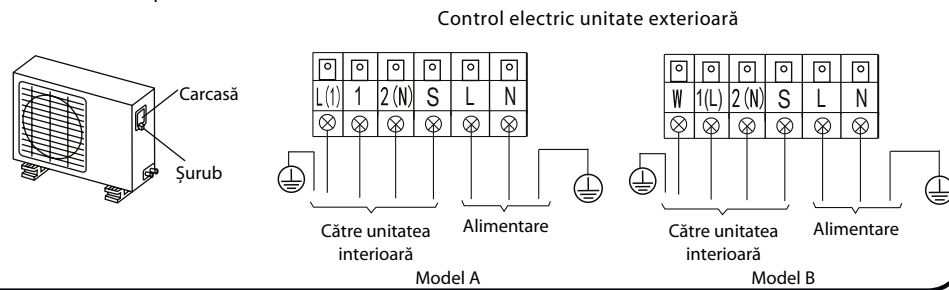

5 VERIFICARE FINALĂ

NOTĂ: Lungimea de țevă va afecta eficiența și capacitatea de energie a unității. Eficiența nominală este testată în baza lungimii conductei de 5 metri.

1. Purjare a aerului

- Tubulatura dintre unitatea interioară și exterioară trebuie să fie testată pentru scurgeri și pentru a elimina condensul și umezeala din sistem
- Verificați dacă fiecare tub (gaz și lichid) dintre unități interioare și exterioare au fost conectate în mod corespunzător și toate cablurile au fost conectate corespunzător.
- Lungime țevă și cantitate de agent frigorific:

Lungime țevă	Metoda folosită	Cantitate adițională de freon
Mai puțin de 5 m	Pompă vacuum	
Mai mult de 5m	Pompă vacuum	Lichid: φ 6.35mm R22: (Lungime țevă-5)x30g/m R410A: (Lungime țevă-5)x20g/m
		Lichid: φ 9.52mm: R22: (Lungime țevă-5)x60g/m R410A: (Lungime țevă-5)x40g/m

- Pentru modelul de agent frigorific R410A, asigurați-vă că refrigerantul adăugat în aparat este în formă lichidă
- Când mutați aparatul în alt loc, folosiți pompă de vid pentru a efectua evacuarea.

ATENȚIE

- Deschideți tija supapei până când se lovește de dop. Nu încercați să-l deschideți și mai mult
- Strângeți bine capacul tijei supapei cu o cheie sau altele asemenea.
- Strângeți valve de capac. Vezi figura alăturată.

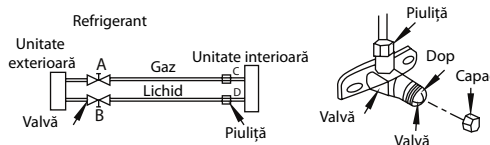

2. Când utilizați pompa de vid

1. Strângeți complet piulițele pentru A, B, C, D, conectați conducta cu supapa și furtunul de încărcare la un port de încărcare a supapei de gaz
2. Conectați racordul furtunului de încărcare la pompa de vid.
3. Deschideți complet mâner jos al supapei multiple.
4. Acționați pompa de vid pentru a evacua aerul din conducte. După ce a început evacuarea, slăbește ușor piulița de la supapă pe partea de gaz și verificați dacă aerul pătrunde. (Zgomotul pompei de vid se schimbă și un contor indică 0 în loc de minus).
5. După ce evacuarea este completă, închideți complet mânerul jos a supapei de colector și opriți funcționarea pompei de vid.
6. Rotiți tija de la robinet B aproximativ 45 grade în sens invers acelor de ceasornic timp de 6 ~ 7 secunde după ce gazul iese, apoi strângeți din nou piulița. Asigurați-vă că afișajul de presiune în indicatorul de presiune este un pic mai mare decât atmosfera de presiune.
7. Scoateți furtunul de încărcare de la furtunul de încărcare de presiune joasă.
8. Deschide complet supapele B și A.
9. Strângeți bine capacul de la supape.

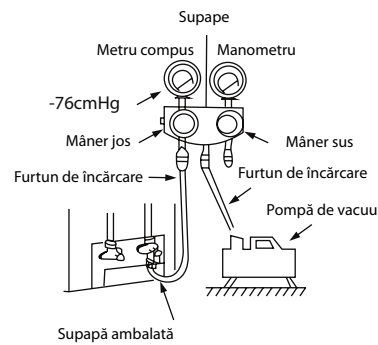

3. Verificare de siguranță a scurgerilor

1. Metoda cu apă și săpun:
Aplicați apă cu săpun sau un detergent neutru lichid pe interiorul conexiunii cu o perie moale pentru a verifica scurgerile din punctele de legătură ale conductelor. Dacă ies bule, se indică faptul că conductele au scurgeri.
2. Detector de scurgeri:
Folosiți detectorul de scurgeri pentru a verifica scurgeri.

ATENȚIE

A: Supapă presiune joasă B: Supapă presiune înaltă C și D sunt capetele de conectare la unitatea interioară

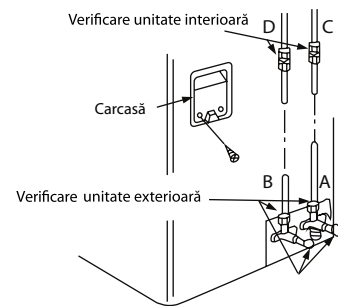

4. Verificarea funcționării

Efectuați proba după finalizarea verificărilor scurgerilor de gaze la conexiunile țevilor și a cablurilor electrice

- Verificați că toate tuburile și cablurile au fost conectate corect
 - Verificați dacă vanele de serviciu de gaz și lichid laterale sunt complet deschise
1. Conectați alimentarea, apăsați butonul ON / OFF de pe telecomandă pentru a porni aparatul.
 2. Utilizați butonul MODE pentru a selecta COOL, HEAT, AUTO și FAN pentru a verifica dacă toate funcțiile sunt în parametri optimi.
 3. Atunci când temperatura ambientală este prea scăzută (mai mică de 17 grade C), aparatul nu poate fi controlat de către telecomandă pentru a rula în modul de răcire, operarea manuală poate fi activată. Operarea manuală este folosită doar atunci când telecomanda este dezactivată sau este necesară întreținerea.
 - Țineți panoul și ridicați panoul până la un unghi la care rămâne fix cu un sunet de clic.
 - Apăsați butonul Manual de control pentru a selecta AUTO sau COOL, unitatea va funcționa sub Modul AUTO sau COOL (vezi Manual de utilizare pentru detalii).
 4. Operațiunea de testare ar trebui să dureze aproximativ 30 de minute.

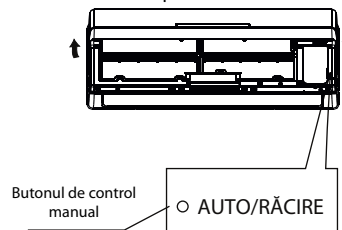

1 PRECAUȚII LA INSTALAREA UNITĂȚII EXTERNE

- Instalați unitatea exterioară pe o bază rigidă pentru a preveni creșterea nivelului de zgomot și vibrații.
- Determină direcția de evacuare a aerului astfel încât aerul evacuat nu este blocat.
- În cazul în care locul de instalare este expus la vânt puternic, cum ar fi pe litoral, asigurați-vă că ventilatorul funcționează corespunzător prin punerea unității longitudinal de-a lungul peretelui sau cu ajutorul unui scut.
- În special în zone cu vânt, instalați unitatea pentru a preveni admiterea de vânt. În cazul în care este nevoie de suspendarea unității, suportul de instalare ar trebui să țină cont de cerința tehnică în instalare. Peretele de instalare ar trebui să fie din cărămidă plină, beton sau alte materiale asemănătoare, avându-se în vedere acțiuni de consolidare, de amortizare și de sprijin.
- Conexiunea între suport și perete, suport și unitate trebuie să fie fermă, stabilă și de încredere.
- Asigurați-vă că nu există nici un obstacol care poate bloca circulația aerului.

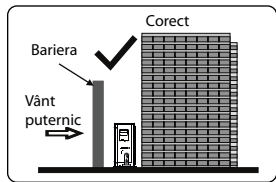
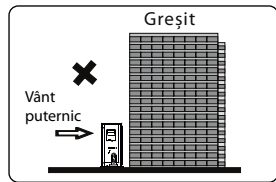

2 INSTALAREA SCURGERII DE CONDENS

NOTĂ: Articulația de evacuare este ușor diferită în funcție de unitatea de exterior

Pentru îmbinarea scurgerii cu garnitura (Fig.A), se potrivesc mai întâi sigiliul cu scurgerea, apoi introduceți scurgerea în orificiul de bază a unității, rotiți 90 de grade pentru a le asambla în siguranță. Pentru a instala evacuarea așa cum se arată în fig. B, se introduce scurgerea în gaura de bază a unității exterioare până când acesta rămâne fixat cu un sunet de clic. Conectarea scurgerii cu un furtun de extensie de evacuare (achiziționate la nivel local), în cazul în care se scurge apă din unitatea exterioară în timpul modului de încălzire

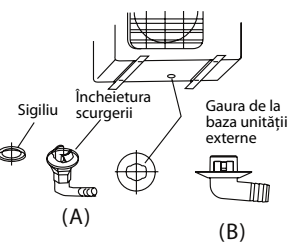

3 CONECTAREA CONDUCTELOR DE GAZ

Tăiere țevi

1. Taie o țevă cu un tăietor de țevă
2. Puneți piulițe și piliți țevile.
3. Țineți ferm țevă de cupru într-o menghină cu dimensiunile arătate în tabelul de mai jos.

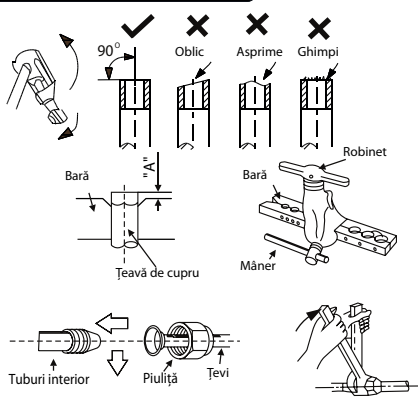

Diametru (mm)	A(mm)	
	Max.	Min.
φ 6.35	1.3	0.7
φ 9.52	1.6	1.0
φ 12.7	1.8	1.0
φ 16	2.2	2.0

Conexiune de strângere

- Aliniați conductele pentru a fi interconectate
- Strânge suficient piulița cu degetele, și apoi strânge cu o cheie și un cuplu de chei așa cum se arată în figură.
- Cuplul excesiv poate sparge țevă în funcție de condițiile de instalare.

Diametru	Strângere cuplu (N.cm)	Strângere cuplu adițional (N.cm)
φ 6.35mm	1500 (153kgf.cm)	1600 (163kgf.cm)
φ 9.52mm	2500 (255kgf.cm)	2600 (265kgf.cm)
φ 12.7mm	3500 (357kgf.cm)	3600 (367kgf.cm)
φ 16mm	4500 (459kgf.cm)	4700 (479kgf.cm)



inventor[®]

Your-conditions

